



Key Lock Replacement Instructions Classic Cash Drawers

Required hand tools: #2 phillips head screwdriver

Procedure:

1. Open the cash drawer and remove the plastic coin and bill tray. Grasp the inner drawer by the drawer front and lift the inner drawer up approximately 15°. Pull the inner drawer out at the inclined angle.
2. Place the key in the vertical position (electrically on-line) with the key's teeth toward the bottom of the drawer. Turn the cash drawer over so that it is resting on its top surface and the opening in the case is facing toward you.
3. Remove the six screws that secure the base to the case. Three screws are located along the back edge of the cash drawer and three screws are located along the front edge. Lift the front edge of the base 2-3 inches and remove the lock rod from lock cam. See the attached diagram. Lift the rear edge of the base and remove the base from the case.
4. The attached diagram shows an exploded view of the lock assembly. Unscrew the M-8E-D fillister screw and remove the lock washer, 1/2 moon washer, cam, and cam stop. The key and lock plug (tumbler assembly) may now be removed from the case and replaced.
5. Install the new lock plug, cam stop, cam, and washers in the orientation shown in the attached diagram. When the cash drawer is upside-down, the key's teeth should be up, toward the bottom of the drawer before re-assembling the components in the lock assembly. Screw the M-8E-D fillister screw into place, securing the assembly.
6. Insert the key and rotate the lock 90° clockwise and 90° counter clockwise. Be sure the the lock rotates freely without sticking or binding at any point during rotation.
7. Replace the base into the case. Be sure to replace the lock rod into the lock cam as shown in the attached diagram. Align the slots in the base with the holes in the case. Replace and firmly tighten the six screws that secure the base to the case.
8. Insert the inner drawer into the cash drawer. Mate the outer slides attached to the inner drawer with the inner slides inside the cash drawer. Lift the inner drawer up approximately 15°, and push the inner drawer into the case. When the plate on the back of the inner drawer has passed the stop plate formed from the base, let the inner drawer rest in the horizontal position.
9. Push the inner drawer to the fully closed position. Resistance to the insertion should be expected because the ball bearings in the slides are forced back to their normal operating position.
10. Verify that the drawer is now operating properly by opening the cash drawer with the key. The drawer should open smoothly through the full extent of the slides.

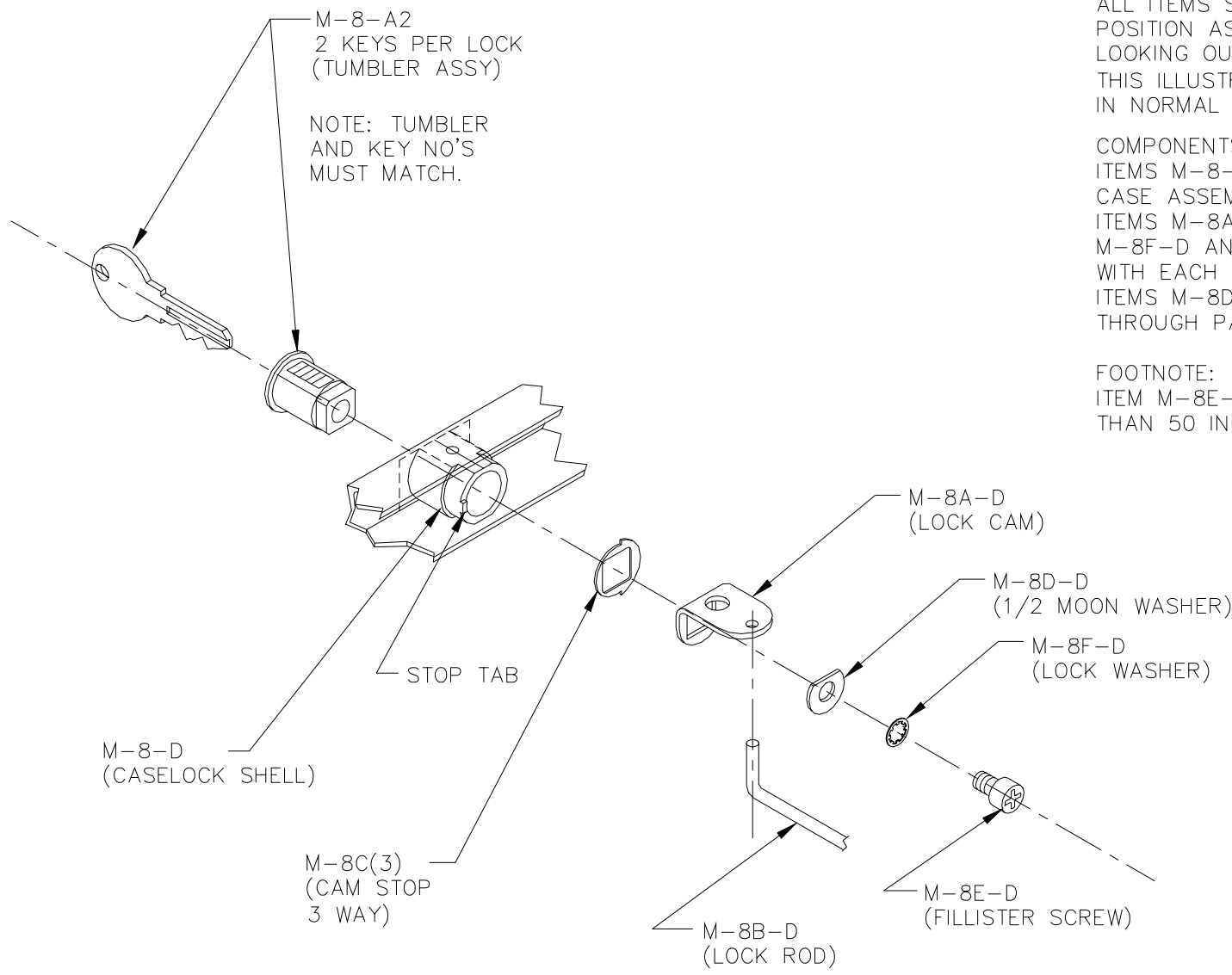

NOTE:
ALL ITEMS SHOWN IN THEIR RELATIVE
POSITION AS VIEWED FROM INSIDE CASE
LOOKING OUT.
THIS ILLUSTRATION SHOWS KEY ASSEMBLY
IN NORMAL UPRIGHT POSITION.

COMPONENTS:
ITEMS M-8-D AND M-8B-D (MOUNTED WITHIN
CASE ASSEMBLY).
ITEMS M-8A-D, M-8C(3), M-8D-D, M-8E-D
M-8F-D AND M-8G-D (BAGGED AND SHIPPED
WITH EACH UNIT).
ITEMS M-8DB AND M-8KDB (OBTAINABLE ONLY
THROUGH PAR MICROSYSTEMS).

FOOTNOTE:
ITEM M-8E-D MUST BE TORQUED TO NO LESS
THAN 50 INCH POUNDS.



APG/UMI
5250 Industrial Blvd. N.E.
Minneapolis, MN 55421-1012
612-571-5000
PSG 04-29-98
FILE#: M-8ASSY